

## SAPPHIRE® Acoustic Nozzle (1 1/2 in.)

### Description

Data centers and server rooms are continuously improving their efficiencies to store and process more data. Improvements in computing hardware have led to an increase in Hard Disk Drive (HDD) sensitivity to sound. High pressure SAPPHIRE® PLUS systems, used to protect this type of equipment, can produce sound levels that may have adverse effects on noise-sensitive equipment.

The HYGOOD® Acoustic Nozzle is designed for SAPPHIRE PLUS Fire Suppression Systems and decreases the acoustic footprint during discharge while maximizing agent vaporization.

The nozzle directs agent into the hazard area and reduces the sound level during discharge compared with standard nozzles. Flow calculations are used to specify the nozzle orifice size for the correct quantity and distribution of agent.

### Application

The HYGOOD Acoustic Nozzle, in combination with SAPPHIRE PLUS Fire Suppression Systems, is suitable for suppressing fires in hazard areas where sound levels may affect sensitive electronic equipment. Typical applications for the acoustic nozzle include server rooms and data centers.

### Technical Specification

- For use with SAPPHIRE PLUS Fire Suppression Systems
- 360° discharge pattern
- Aluminum body with fiberglass and internal damping materials
- Internal pipe with 16 custom-drilled orifice holes
- Available in 1 1/2 in. (DN40) National Pipe Thread (NPT) size
- Available in 1 1/2 in. (DN40) British Standard Pipe Taper (BSPT) size
- See Figure 1 for 1 1/2 in. nozzle dimensions
- Nozzle drill diameter size must be provided with order.
- Drill diameter determined through a hydraulic flow calculation in the Suppression Design Center (SDC)
- Acoustic nozzle weights:

Description	1 1/2 in.
With pipe coupling	3.6 kg (7.9 lb)
Without pipe coupling	2.6 kg (5.7 lb)



010814

### Maximum Nozzle Limitations

- Area coverage per nozzle: 9.8 m x 9.8 m (32.0 ft x 32.0 ft)
- Protected height: 4.3 m (14.1 ft)
- Installation distance from ceiling: 305 mm (12 in.)

### Dimensions

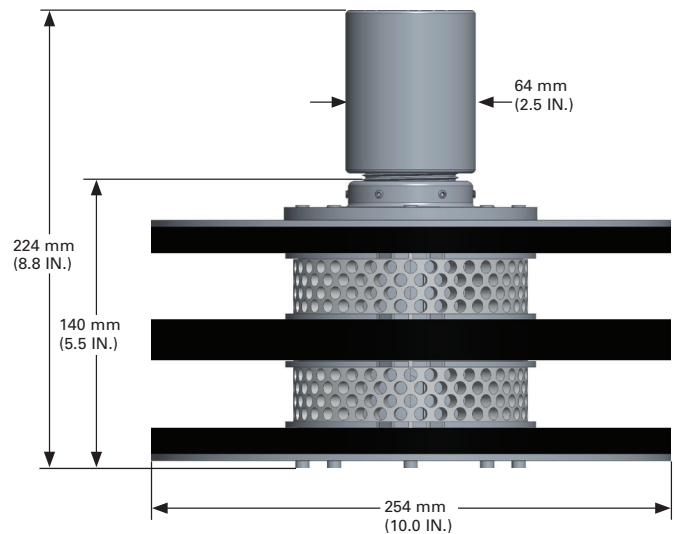

**FIGURE 1**  
**1 1/2 IN. NOZZLE DIMENSIONS**  
010815

**Note:** Use the appropriate nozzle assembly depending on the pipe threads used in the system pipework.

## Sound Performance

**Sound power** is the amount of sound energy produced by a noise source such as a fire suppression system discharge nozzle. The HYGGOOD Acoustic Nozzle is designed to reduce the sound power level produced during a discharge of the SAPPHIRE PLUS Fire Suppression Systems.

**Sound pressure** is the sound received at a location remote from the noise source. The remote location may include HDDs. Sound pressure is the critical sound energy relevant to the effects on the HDDs. The HYGGOOD Acoustic Nozzle is one of the factors that assists in reducing the sound pressure to an acceptable level, which reduces the risk of HDD damage. The sound pressure level can be further improved by a number of other factors including the positioning of the nozzles, optimizing the room acoustics, use of sound absorbing room construction materials, and the installation of sound absorption panels.

A summary of the estimated nozzle peak acoustic sound power across 500 Hz to 10 kHz frequencies at different agent flow rates is shown in Figure 3.

**Note:** The values stated in Figure 3 are based on actual testing performed by Johnson Controls.

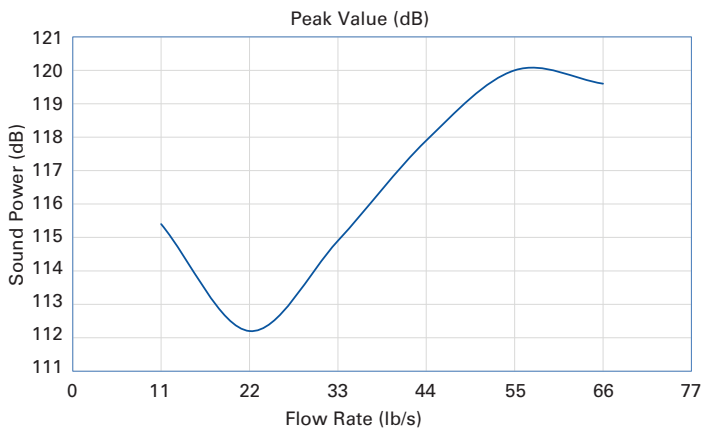

**FIGURE 3**  
**1 1/2 IN. NOZZLE SOUND POWER VERSUS FLOW RATE**  
010816

**Note:** Verify your specific room characteristics and fire suppression system effects using the Johnson Controls Acoustic Calculator.

Johnson Controls strongly recommends that data center operators review the room acoustics and the fire suppression system features (system pressure, fill density, flow rate, and nozzle pressure). Contact Johnson Controls for help to understand the impact of these measures and estimate the sound pressure level experienced at a given location using the Johnson Controls Acoustic Calculator.

For more information, refer to the Johnson Controls White Paper: *The Impact of Sound on Computer Hard Disk Drives (HDD) and Risk Mitigation Measures* (Form No. T-2016367), available on [www.hygood.com](http://www.hygood.com).

## Ordering Information

Part No.	Description
419620	SAPPHIRE Acoustic Nozzle, NPT, 1 1/2 in.
449621	SAPPHIRE Acoustic Nozzle, BSPT, 1 1/2 in.

**Note:** The converted metric values in this document are for dimensional reference only and do not reflect an actual measurement.

HYGOOD, SAPPHIRE, and the product names listed in this material are marks and/or registered marks. Unauthorized use is strictly prohibited.